

## auto electrical parts

### Technical Information Sheet

**Part No. 0-441-00**

Ultra high intensity Amber 6 x 3W LED flush warning light. 12/24volt unit with 20 programmable flash sequences. Two bolt fixing. IP68. CE, ECE R65 Class 1 and SAE Class 1 approved.

#### Additional information

Red wire +ve supply  
Black wire -ve ground  
White wire alternating flash  
Yellow wire synchronization and flash pattern



#### Technical Drawing (not to scale)

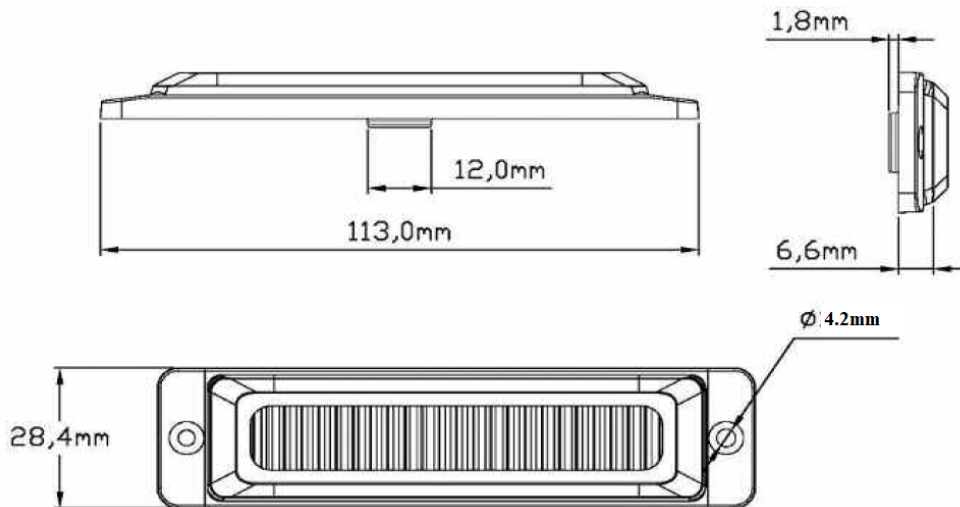

#### Specification

Type	Ultra high intensity LED
Colour	Amber
Number of LEDs	6 x 3 watt
Voltage	12/24 volt dc
Current	0.70 amps at 12volts
Flash patterns	20
Base	Aluminium
Operating temperature	-20C - +50C
Protection	IP68
Weight	40g
Dimensions	l 113 x w 28.4 x h 9mm
Compliance	CE, ECE R65 Class 1, SAE Class 1

The information contained in this document is correct to the best of our knowledge at the time of printing. However, specifications may change at any time without notice.