



**ECE R10 / R65 Lightbar 52W 760mm
Part 0-443-40**



WARNINGS

Before using this unit please read these instructions carefully. Take special care to follow the warnings and safety suggestions listed below. Keep these instructions for future reference. There are no user-serviceable parts within the unit, refer servicing to qualified service personnel.

GENERAL

Durite 0-443-40, 41, 42 Lightbars are versatile and powerful warning devices suitable for a range of vehicles types and duties. There are numerous options and lengths available and the lightbars are mounted to the vehicle using the supplied mounting kit.

The 0-443-40, 41, 42 series is suitable for many vehicle applications. They feature reflective LED modules, a durable aluminium chassis and polycarbonate lens. Available with 10 flash patterns. The LED colour is amber providing a full 360 degree of bright scene lighting.

DIMENSIONAL DRAWING

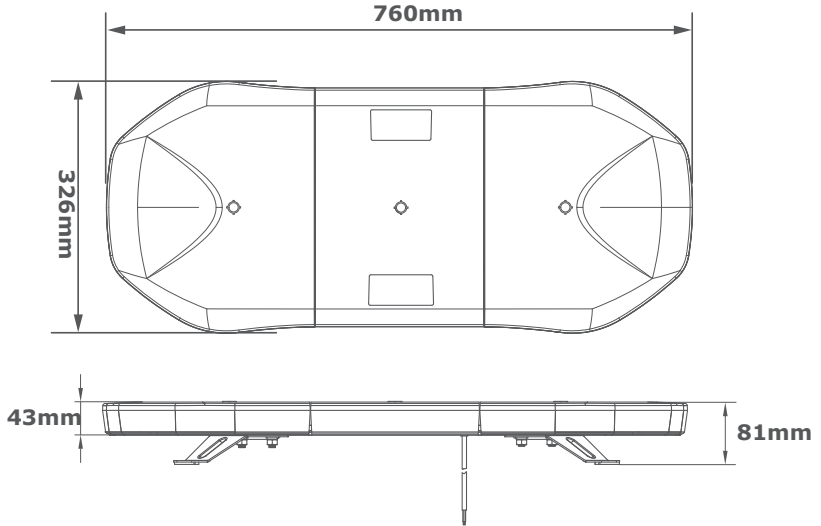

FLASH PATTERNS

Sequence	Description	FPM
1	Alternating single flash	230
2	Alternating double flash	162
3	Alternating four flash	90
4	Single flash	150
5	Double flash	162
6	Four flash	96
7	Randomness combination 1	
8	Randomness combination 2	
9	Randomness combination 3	
10	Randomness combination 4	

MOUNTING

Before proceeding with installation, plan all cable and wiring routing. Select the mounting location for the light bar on a flat smooth surface and centre the unit across the width of the vehicle. The mounting location for the lightbar should be chosen such that the lightbar is level and visibility to traffic is optimised. Mounting should be such that there is no less than 12mm (1/2") clearance between the roof and the lightbar at any point.

1. Insert the heads of the M8 mounting bolts into the opening at the end of the slots on the base of the lightbar. Loosely fasten mounting feet to base extrusion using M8 nuts and spring washers (refer to diagram).
2. Determine the location of the lightbar and the best route for wiring.
3. Loosen the M8 nuts to allow the mounting feet to slide along the base. Place the lightbar on the vehicle in the determined location and slide the mounting feet into position. It is suggested that positioning of the feet be symmetrical and positioned near the curved edges of the roof where the roof is the strongest.
4. With the feet positioned, mark the location of the mounting hole centres on the roof. Remove the bar and drill the 8.5mm -10.0mm (11/32") mounting holes as marked. Note the centre distance between the mounting holes in a foot is 135mm (5 5/16").
5. Insert M8 Coach bolts into the mounting feet (refer to diagram) and tighten the M8 nuts holding the feet to the base of the lightbar.
6. Mount the light bar, with the bolts going through the holes drilled in step 4, routing the wire as planned in step 2 (refer to diagram). See the wiring section of this manual for further wiring instructions. Install washers and M8 Nyloc nuts, and secure the unit.

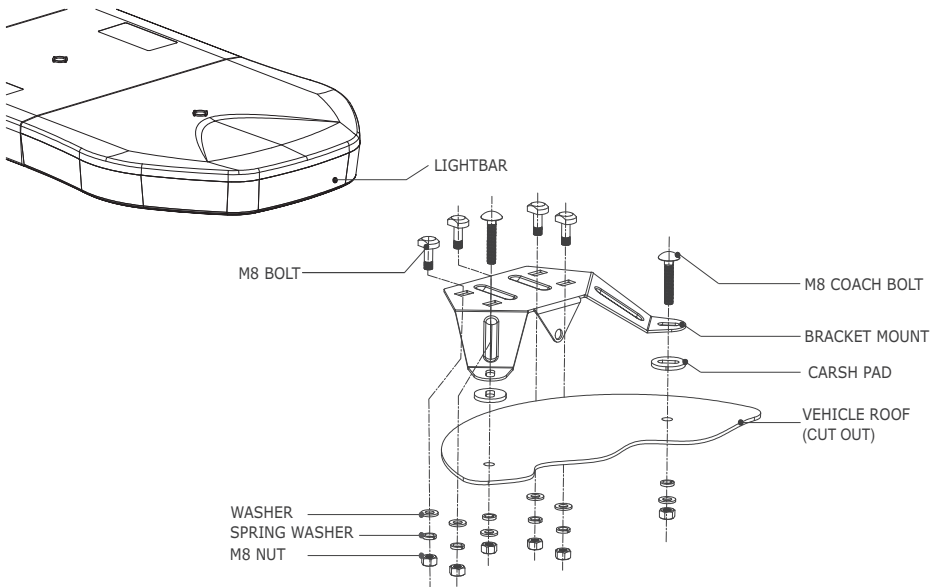

WIRING INSTRUCTION

Notes for consideration:

1. Larger wires and tight connections will provide longer service life for components. For high current wires it is highly recommended that terminal blocks or soldered connections be used with heat shrink tubing to protect the connections. Do not use insulation displacement connectors.
2. Route wiring using grommets and sealant when passing through compartment walls. Minimize the number of splices to reduce voltage drop. High ambient temperatures (e.g. under hood) will significantly reduce the current carrying capacity of wires, fuses and circuit breakers.
3. Particular attention should be paid to location and method of making electrical connections and splices to protect these points from corrosion and loss of conductivity.
4. Ground termination should only be made to substantial chassis components, but preferably to the vehicle battery
5. Circuit breakers are very sensitive to high temperatures and will 'false trip' when mounted in a hot environment or operated close to their capacity.

Wiring up the lightbar:

1. Route wires from the vehicle positive (battery, alternator, fuse block) to the switch panel in the cab. Use suitable high temperature vehicle cable if it passes through the engine compartment. Install an 8A fuse as close to the point of tapped power as possible.
2. Connect the wires to the positive side of the additional control switch panel with quick connect terminals or by soldering.
3. After the light bar has been mounted, route the wiring harness into the vehicle to the switch panel location.
4. Connect the wires of the light bar wiring harness to the switched side of each switch. See the below diagram for wire colour key.
5. Connect the light bar cable Black wire (-VE) to a solid ground connection on the vehicle (Ideally, direct to the battery negative terminal).
6. Use cable ties and grommets to secure and protect all cables and wires.

*This unit is a safety device and it must be connected to its own separate, fused power point to assure its continued operation should any other electrical accessory fail. Do not wire in parallel with any other accessory. Disconnect the battery before wiring up the light bar, to prevent accidental shortin, arcing and/or electrical shock.

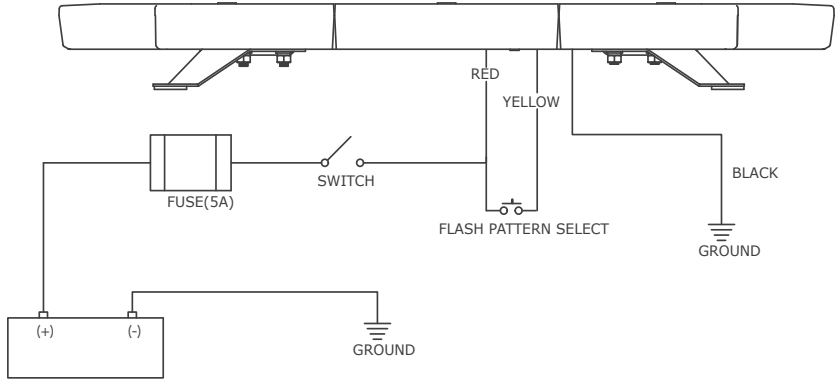

SPECIFICATION

Product Type.....	Warning Lightbar
LED Colour.....	Amber
Voltage.....	12/24VDC
Max Power.....	52W
Fuse.....	8A
Current Draw 12VDC.....	3.98A
LED's.....	104 LED's (0.5W each)
LED Type.....	SMD
Flash Patterns.....	10 Total
Optics.....	TIR
Protection.....	IP67
Mounting.....	Carbon Steel Bracket Mount
Flying Leads.....	2.5M
Lens Material.....	PC
Lens Thickness.....	3mm
Operating Temp.....	-40°C ~ +65°C
Storage Temp.....	As above
Weight.....	9.3Kg
Dimensions.....	Please see page 2 dimensional drawing
Certificates.....	E Marked, ECE R10 & ECE R65.