



0-857-66 - 24VDC 1500W PSW INVERTER

Durite's 24VDC 1500W Pure Sine Wave Heavy Duty Inverter

Key Features:

- Robust Construction
- Wide Range Input Voltage 22.0 - 30.0VDC
- LCD Panel Display with fault code reader / diagnostics
- Fan cooled
- E Marked R10.06 EMC

THE TRUSTED QUALITY BRAND FOR PROFESSIONALS



Warnings

Read all instructions before attempting to install or use the inverter.

High voltage, 230 volts AC, is generated by this unit.

Do not use with wet hands or near water.

This unit is only suitable for 24 volt electrical systems with negative earth.

To supply 230 volt 50 Hz loads of <1500 watts.



Do not connect to any other AC power source.

Installation Instructions

1. Disconnect all battery leads, -VE leads first, before installing the inverter.
2. Locate a suitable position for the inverter and fit securely. The site chosen should be:
 - (a) Well ventilated.
 - (b) Not exposed to direct sunlight or heat source.
 - (c) Away from water or moisture.
 - (d) Out of reach of children.
 - (e) Away from any flammable or heat sensitive substance.
3. Connect the black 24 volt -VE terminal to the negative side of the supply source and the red 24volt +VE terminal to a fused positive supply source. Use a minimum of 16.0mm² cable and keep all cable runs as short as possible. Fuse size 100 Amp Max.
4. Connect the inverter case ground terminal to the chassis ground when installing in a vehicle, the vessel's grounding system in a boat or to earth in a fixed location. The case ground terminal is connected to the ground terminal in the AC outlet socket.
5. If using the optional remote control ; fix the remote control in a suitable position and insert the connector into the remote control socket on the inverter control panel.

Operating Instructions

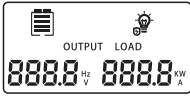
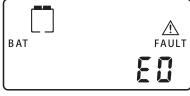
1. Ensure that the inverter is supplied by a 24 - 30 volt DC negative earth system and that the load requires <1500 watts at 230 volt 50Hz AC.
2. Plug the appliance into the inverter and then turn on the inverter's power switch; hold for 3-5 seconds. The LCD will illuminate to indicate AC power is present, then switch on the appliance. Always turn on the inverter before turning on loads individually.
3. Switch off the inverter when not in use or when heavy current is drawn from the DC supply, e.g. when starting an engine from the same supply source,
4. If the inverter beeps, but is still supplying AC output, this indicates a low supply voltage; switch off the inverter to preserve battery voltage. If left on the inverter will automatically shut down when the supply voltage falls to approximately 19 +/- 0.6 volts.
5. The fault light indicator illuminates when the inverter has shutdown due to output short-circuit or gross overloading. If this occurs switch the inverter off and correct the cause before switching the inverter on again. For more detail please see below :

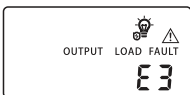
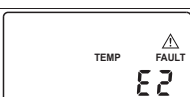
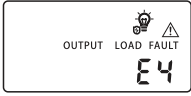
Function	State description			Restart work method
	LCD display	Alarm	AC output	
Input under voltage alarm		Yes Di.....	Yes	Stop using , recharge the battery. Or replace new batteries
Input under voltage shut down		Yes Di...Di...	No	When the input voltage rises to 24V +/- 0.4V, the inverter will automatically resume operation.
Input over voltage shut down		Yes Di...Di...	No	When the input voltage drops to 28V +/- 0.4V, the inverter will automatically resume operation.
Over load shut down		Yes Di...Di...	No	Reduce the load in the rated power range. Restart inverter recovery work. Or Wait 1-3 minutes for the inverter to recover automatically.
Over temperature shut down		Yes Di...Di...	No	When the inside temperature return to related range.
Output short-circuit		Yes Di...Di...	No	After troubleshooting, restart the inverter by manual to resume work.

Display and Controls

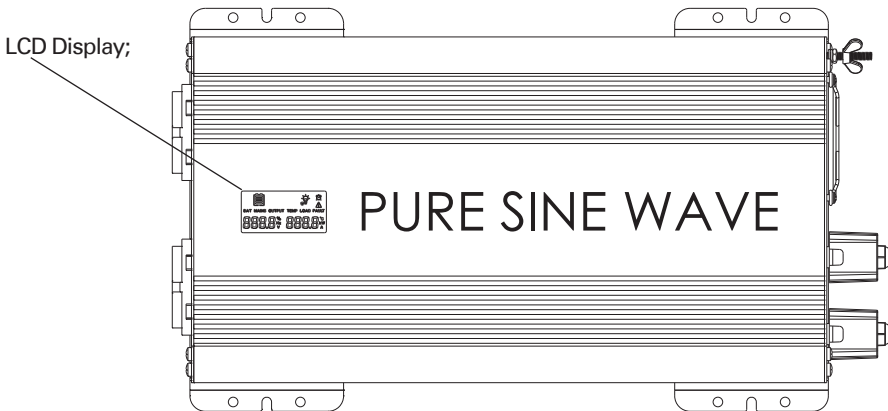
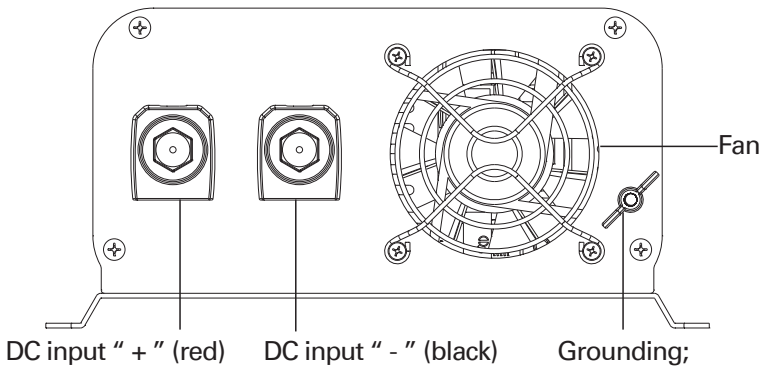
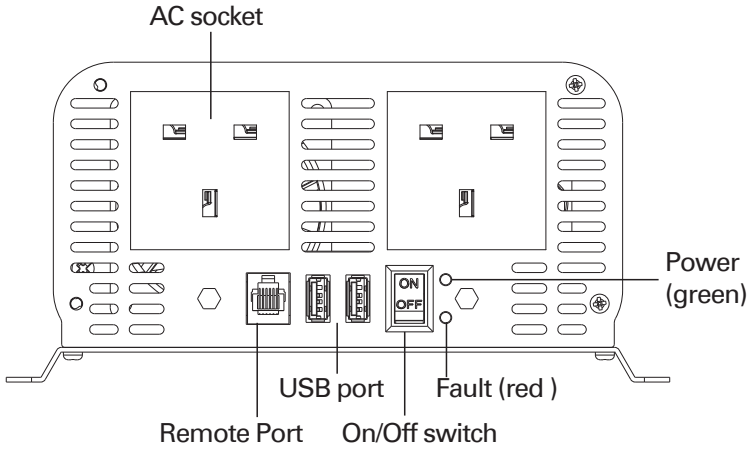

Remote Control

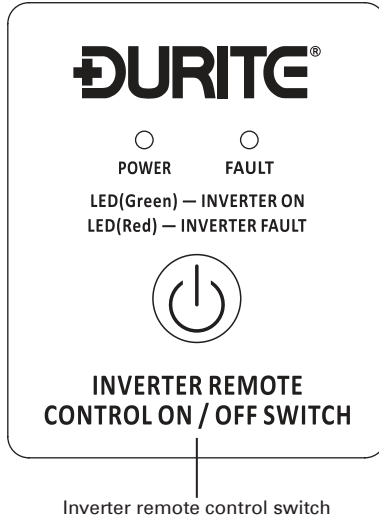

- ▲ Remote Control Usage : Please keep "OFF" position for switch of inverter, otherwise remote control function is invalid.

Status instruction for LED light of Remote Control Panel :

Function	LED light	
	Red	Green
Input under voltage alarm	ON	OFF
Input under voltage shut down	ON	ON
Input over voltage shut down	ON	ON
Over load shut down	ON	ON
Over temperature shut down	ON	ON
Output short-circuit	ON	ON

Dimensional Drawing

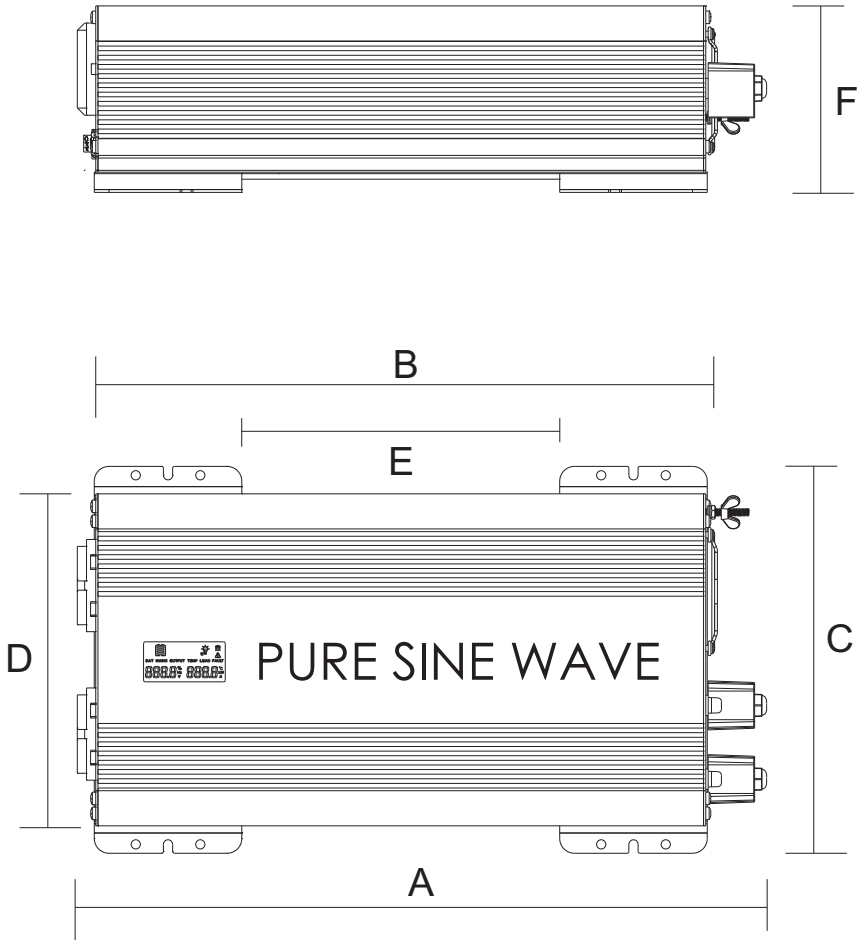

A (mm)	B (mm)	C (mm)	D (mm)	E (mm)	F(mm)
374	332	210	180	173	101

TECHNICAL SPECIFICATIONS

Input	Rated input voltage	DC 26V
	Operating voltage range	DC 22V-30V
Output	Output voltage	AC 230V +/- 10%
	Output frequency	50Hz +/- 1Hz
	USB Output (2 USB total)	DC 5V, 2100mA
	Continuous power	1500W
	Peak power	3000W
	Output Wave	Pure sine wave
Max Efficiency		≥ 85%
24V Input No load current draw		≤ 0.7A
Low voltage	Input Low-Voltage Alarm	DC 21V +/- 0.4V
	Input Low-Voltage Shut Down	DC 19V +/- 0.4V
	Low-Voltage Recovery Voltage	When the input voltage rises to 24V +/- 0.4V, the inverter will automatically resume operation.
Over voltage	Input Over Voltage Shut Down	DC 32V +/- 0.4V
	Over-voltage Recovery Voltage	When the input voltage drops to 28V +/- 0.4V, the inverter will automatically resume operation.
Over load	Over-load protection	Yes (1550 ~ 1800W)
	Overload Recovery	Reduce the load in the rated power range. Restart inverter recovery work. Or Wait 1-3 minutes for the inverter to recover automatically.
Over temp	Over Temperature protection	Yes
	Over Temperature Recovery	When the temperature inside the inverter decreases to the set point, the inverter will back to work automatically.
Short circuit	Output Short Circuit protection	Yes
	Short Circuit Recovery	After troubleshooting, restart the inverter by manual to resume work
Reverse protection		Reverse connection will blow the fuse, fuse replacement with the same specifications can fix the inverter; Reverse connection will cause irreparable damage to the inverter!
The Best Working Temperature		5 - 35°C
Fuse		25A*4
Cooling method		By Fan
LCD display information		Input voltage , Load power , Output frequency , Output current , Battery power , Fault code (E0 : Low volt , E1 : Over volt , E2 : Over temp , E3 : Over load , E4 : Output short circuit)
Remote control		RJ12 port , 6m cable